

An Adaptive Active Damper for Improving the Stability of Grid-Connected Inverters with Fuzzy Logic Controller

Umesh Kumar¹, Indrajeet Kumar², Priyank Gour³

Research Scholar, Department of Electrical and Electronics Scope College of Engineering, Bhopal (M.P.)¹

Assistant Professor, Department of Electrical and Electronics Scope College of Engineering, Bhopal (M.P.)^{2,3}

Abstract

In this paper a fuzzy controlled active damper circuit is introduced in a grid connected inverter system with instability issues. An adaptive active damper can be connected to the point of common coupling (PCC), which can automatically regulate a virtual resistor to the critical value to stabilize the system. Furthermore, a harmonic-current-reference compensation method is adopted to make the active damper more accurately simulate the virtual resistor in a wide frequency range. This paper investigates the harmonic-current-reference compensation for the stationary α - β frame, synchronous d-q frame, and decoupled synchronous d-q frame-controlled three-phase adaptive active damper. With the proposed method, the active damper controls the active and reactive power directly and improves the stability of the grid-connected inverters under weak grid at the same time. The simulation of the proposed system with PI and FIS controllers are carried out in MATLAB Simulink software with comparative analysis between both the test systems.

Keywords: Adaptive active damper, grid connected inverters, harmonic current reference Compensation technique, PI controller, FIS controller.

1. Introduction

As the breach of distributed power generation systems sets out high, the power grid displays more like a weak grid which attributes a large set of grid impedance values. Even though the inverters are designed to be stable during stiff grid, but they often become unstable when connected to the weak grid via point of common coupling. Conventionally, an impedance-based stability criterion is used to evaluate the stability of the system. This makes use of consideration of two points where one is under stiff grid condition, the grid connected inverter is stable and the second being the ratio between grid impedance and output impedance of the inverter satisfies the Nyquist criterion. In order to improve the stability of the grid either the control parameters must be optimized or the control

algorithm of the grid connected inverter must be modified in such a way that the output impedance becomes positive. These methods make the system robust and stable against the variations in the grid impedances but at the same time there is need of change in the internal configuration of the grid connected inverters, power circuit and control algorithms, which are usually modularly designed.

In an alternative method, an external damping resistor is connected in parallel at the point of common coupling so as to damp out the resonances between the grid and grid connected inverters. This resistor when updated with power electronic converters so as to eliminate the addition power loss in the system is termed as **active damper**.

Usually, different types of filtered grid connected inverters are used in conjugation with the active dampers. These filtrations may be of L type, LC type, LCL type etc. where L type is the basic form of filtering used. In order to reduce the active damper's voltage rating, a capacitor is used in series with the filter. It also maintains the fundamental component of the voltage at point of common coupling. The use of LCL filtered grid connected inverter along with active damper showcases better attenuation of the harmonics present in the switching frequency, small construction size and feasible as compared to others.

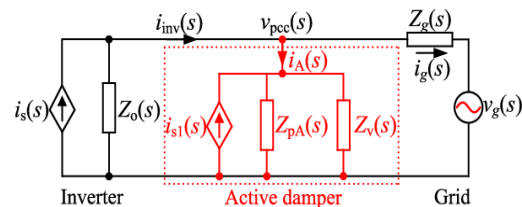

Fig.1 Active Damper System Connection

The active damper showcases similar operating principle as that of resistive active power filter, by simulating a virtual resistor during harmonic frequencies and thereby controls the output current harmonic components in such a way that it is proportional to the point of common coupling voltage harmonics. Also the active damper acts as a grid connected inverter by injecting currents into the grid. The power rating of the active damper is kept lower

as compared to the grid connected inverters in the system so as to achieve a wide control band width and to obtain high switching frequencies.

2. Methodology

This dissertation mainly deals with the adaptive active damping which is a process of adding an external resistor in parallel at the point of common contact so as to damp out the resonance between the grid and the grid connected inverters. In modern electronics this resistor is been replaced with power electronic converters and is termed as active damper and the process is termed as active damping. Figure 2 shows the proposed model of the dissertation that shows the inclusion of active damper in a grid connected inverter under weak grid. Here the active damper is implemented with the help of an LCL filtered grid connected inverter.

The working of adaptive active damper is similar to that of resistive active power filter that simulates a virtual resistor with harmonic frequencies in such a way that the output current harmonic components are proportional to point of common contact harmonic voltage.

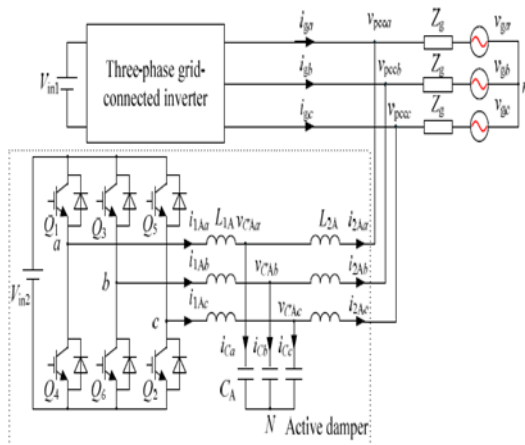

Fig. 2 Circuit Diagram of Three phase grid connected inverter with adaptive active damper

There are various operational principle used by the active damper that is discussed below briefly:

2.1 Active damper under hybrid frame

The hybrid frame uses the combination of the harmonic current reference and filter capacitor current feedback from the stationary α - β frame and the direct control of active and reactive power of the synchronous d-q frame.

In short, the adaptive active damper automatically simulates a virtual resistor so as to damp the resonance at the point of common coupling and improves stability of grid connected inverters under weak grid. Also, it can also be taken as a LCL type grid connected inverter that injects current into the grid.

2.2 Fuzzy Logic Controller

Fuzzy Logic Controller: In order to implement control algorithm of a shunt active filter the DC side capacitor voltage must be sensed and compared with reference value. The error and change in error are two inputs for fuzzy processing. In fuzzy controller the control action is determined by sets of linguistic rules. The advantage is it does not require mathematical model and works with imprecise inputs.

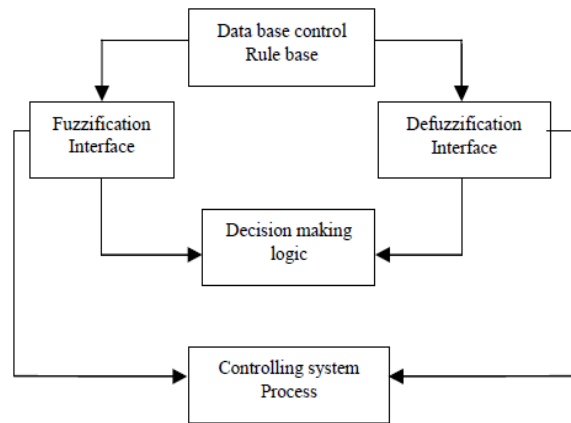

Fig.3 Fuzzy Inference System

2.3 Design of Control Rules

Fuzzification:

The fuzzy control rule design involves defining the rules that relate the input variables to the output model properties. Since fuzzy logic controller is independent of system model, the design is majorly based on the intuitive feeling and experience of the process. The rules are expressed in English like language with syntax such as If {error e is A and change of error Δe is B} then {control output is C}. For better control performance finer fuzzy petitioned subspaces (NL, NM, NS, ZE, PS, PM, PB) are used.

2.5 Advantages of Fuzzy Control

The advantages of fuzzy control over the adaptive control can be summed as follows:

- It relates output to input, without much understanding all the variables, permitting the design of system to be more accurate and stable than the conventional control system. the linguistic, not numerical; variables make the process similar to that of human thinking process The fuzzy controller uses two input membership variables; error E and change in error dE . The fuzzy function has only one output. The function considered is 'mamdani' function with seven membership functions in each variable. The input membership functions are in gauss format and are shown in figure 3.

3. Simulation Results & Analysis

In this paper we are making use of MATLAB and Simulation Software for the development and analysis of an adaptive active damper for a grid connected inverter controlled with the help of PI controller and FIS controller.

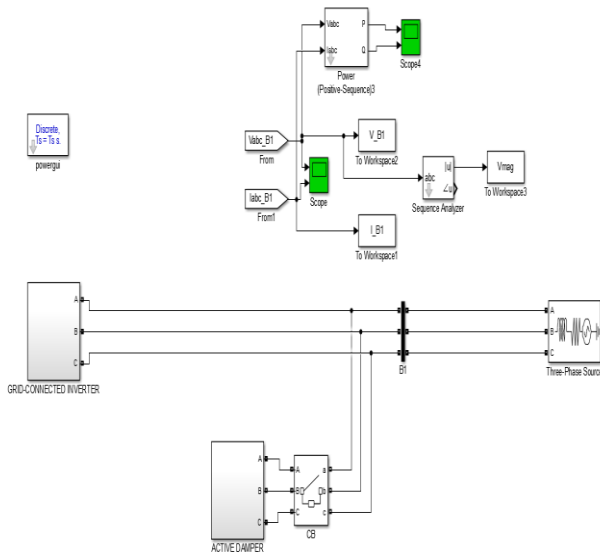

Fig. 4 Proposed System

3.1 Simulation Parameter

Table 1 Parameter of Active Damper

PARAMETERS	VALUE
DC Side Voltage	700 V
Grid voltage (RMS) V_g	220V
Port current sensor gain H_{Ia}	0.68
current sensor gain H_{icA}	0.42
DC-side capacitor C_{dcA}	150 μ F
Fundamental Frequency	50 Hz
Inverter-side inductor L_f	1.5 mH
Filter capacitor C_f	1.5 μ F
Modulation index (PWM)	0.95
Proportional constant	$K_p=5$
Integral constant	$K_i=10$
Grid-side inductor L_2	200 mH
Switching Frequency f_{swA}	60 kHz

3.2 Simulation Model Descriptions

- **Description 1** the below figure depicts the proposed test system that contains a conventional source connected in parallel to the inverter fed with DC source. The grid connected inverter along with the active damper is connected to the PCC using a circuit breaker at a time point of 0.2 second.

3.3 Simulation Result Analysis

In order to obtain the simulation results of the above-described model, the simulation is been run for a time period of 1 sec. The voltage and current are recorded both with and without active damper circuit. At a time point of 0.2 sec the active damper circuit is introduced to the grid. The below figures depicts the traced graphs.

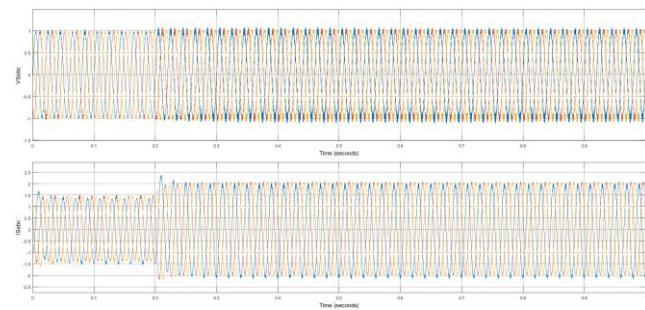

Fig.5 PCC Voltages and Currents with FIS Controller

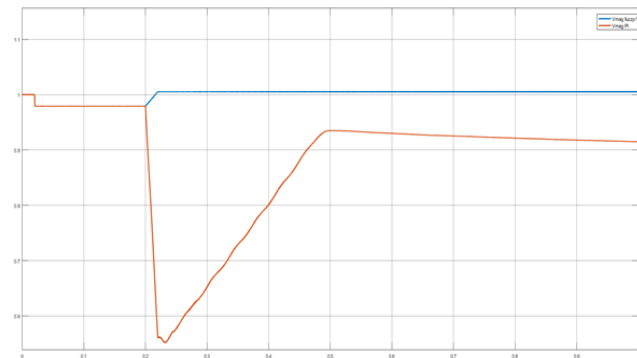

Fig.6 Comparison of Vmag at PCC with PI and FIS Controller

4. Conclusion

The analysis of the above results can be concluded by saying that the voltage magnitude settles faster when we make use of FIS controlled active damper and it remains stable somewhat near to 1pu. But in case of PI controlled active damper there is slow settling of the voltage magnitude which is neither stable nor near to 1 pu. FFT analysis tool is been used to analyze the THD of the PCC voltage. It can be inferred from it that when the grid system is connected with different controller based active damper circuits, the harmonics thus obtained is less in case of FIS controller as compared to PI controller.

Reference

- [1] M. Liserre, R. Teodorescu, and F. Blaabjerg, "Stability of photovoltaic and wind turbine grid- connected inverters for a large set of grid impedance values," IEEE Trans. Power Electron., vol. 21, no. 1, pp. 263–272, Jan. 2006.

-
- [2] J. Sun, "Impedance-based stability criterion for grid-connected inverters," *IEEE Trans. Power Electron.*, vol. 26, no. 11, pp. 3075–3078, Nov. 2011.
 - [3] D. Pan, X. Ruan, C. Bao, W. Li, and X. Wang, "Optimized controller design for LCL-type grid-connected inverter to achieve high robustness against grid-impedance variation," *IEEE Trans. Ind. Electron.*, vol. 62, no. 3, pp. 1537–1547, Jul. 2014.
 - [4] L. Harnefors, L. Zhang, and M. Bongiorno, "Frequency-domain passivity based current controller design," *IET Power Electron.*, vol. 1, no. 4, 841 pp. 455–465, Dec. 2008.
 - [5] L. Harnefors, A. G. Yepes, A. Vidal, and J. Doval - Gandoy, "Passivity based controller design of grid-connected VSCs for prevention of electrical resonance instability," *IEEE Trans. Ind. Electron.*, vol. 62, no. 2, pp. 702–845 710, Feb. 2015.
 - [6] J. He, Y. W. Li, D. Bosnjak, and B. Harris, "Investigation and active damping of multiple resonances in a parallel-inverter-based micro grid," *IEEE Trans. Power Electron.*, vol. 28, no. 1, pp. 234–246, Jan. 2013.
 - [7] X. Wang, F. Blaabjerg, M. Liserre, Z. Chen, J. He and Y. W. Li, "An active damper for stabilizing power electronics based ac systems," *IEEE Trans. Power Electron.*, vol. 29, no. 7, pp. 3318–3329, Jul. 2014.
 - [8] X. Wang, Y. Pang, P. C. Loh, and F. Blaabjerg, "A series-LC-filtered active damper with grid disturbance rejection for ac power-electronics based power systems," *IEEE Trans. Power Electron.*, vol. 30, no. 8, pp. 4037-4041, Aug. 2015.
 - [9] H. Bai, X. Wang, P. C. Loh, and F. Blaabjerg, "Passivity enhancement of grid-tied converters by series LC-filtered active damper," *IEEE Trans. Ind. Electron.*, vol. 64, no. 1, pp. 369–379, Jan. 2017
 - [10] L. Jia, X. Ruan, W. Zhao, Z. Lin and X. Wang. "An Adaptive Active Damper for Improving the Stability of Grid-Connected Inverters Under Weak Grid," *IEEE Trans. Power Electron.*, accepted.
 - [11] P. A. Dahono, "A control method to damp oscillation in the input LC filter of AC-DC PWM converters," in *Proc. IEEE PESC*, Cairns, Australia, 2002, pp. 1630–1635.
 - [12] W. Li, X. Ruan, D. Pan, and X. Wang, "Full-Feed forward Schemes of Grid Voltages for a Three-Phase LCL-Type Grid-Connected Inverter," *IEEE Trans. Ind. Electron.*, vol. 60, no. 6, pp. 2237–2250. Jun. 2013.
 - [13] E. Twining and D. G. Holmes, "Grid current regulation of a three-phase voltage source inverter with an LCL input filter," *IEEE Trans. Power Electron.*, vol. 18, no. 3, pp. 888–895, May 2003.